

READ COMPLETE SAFETY INSTRUCTIONS AND INSTALLATION TEMPLATE BEFORE STARTING

ATTENTION INSTALLER:

This product must be installed by a qualified heating and air conditioning contractor. Failure to do so could result in serious injury from electrical shock. This product must be installed in compliance with all local, state and federal codes.

Aprilaire® SMALL BYPASS HUMIDIFIER MODEL 500M AND 500A

⚠ WARNING

- ELECTRICAL SHOCK HAZARD.** Disconnect electrical power to the furnace before starting installation. Failure to do so could result in serious injury from electrical shock.
- SHARP EDGES HAZARD.** Sharp edges may cause serious injury from cuts. Use care when making plenum openings and handling ductwork.
- RISK OF SCALDING.** Water temperature over 125°F can cause severe burns and scald instantly. Shut off the hot water supply before disconnecting or tapping into any hot water supply line.

⚠ CAUTION

RISK OF PROPERTY AND EQUIPMENT DAMAGE.

- Do not install humidifier where freezing temperatures could occur. The water line could freeze and crack causing water damage to the home.
- Do not install humidifier or bypass connection on the furnace jacket.
- Do not install humidifier or bypass connection on a plenum face where the blanked off ends of the cooling coil will restrict air movement through the humidifier.
- Do not set humidity level above recommended or to recommended level if condensation exists on inside windows of any unheated space, as condensation damage may result. Excess humidity can cause moisture accumulation which can allow the possibility for mold growth in the home.
- Do not connect Model 500M or 500A transformer to blower motor wiring. Premature component failure may result.
- When installing Humidifier Control on downflow furnace, ensure blower continues to run after a heat call is satisfied to eliminate high temperatures from damaging the Humidifier Control.
- Do not install humidifier where water pressure exceeds 125 psi, since damage to the humidifier may result. Follow codes in effect concerning pressure reduction.
- Do not install humidifier on systems with greater than 0.4 in. wg pressure differential between supply and return plenums.

SPECIFICATIONS

HUMIDIFIER DIMENSIONS

Width (including solenoid valve): 15 5/8"
Height (including drain spud): 13"
Depth: 10 1/4"

BYPASS DUCT OPENING

6" diameter

PLENUM OPENING

9 1/2"W x 9 1/2"H

WATER FEED RATE

3 gph

ELECTRICAL DATA

24 VAC-60 Hz, 0.5 AMP

RECOMMENDED WIRING DIAGRAMS

(SEE STEP 7 ON BACK AND "HUMIDIFIER CONTROL SAFETY AND INSTALLATION INSTRUCTIONS" FOR DETAILED WIRING INSTRUCTIONS)

Model 500M MANUAL CONTROL

IMPORTANT

USE 120 VAC POWER SOURCE OTHER THAN FURNACE MOTOR CIRCUIT. HOWEVER, THE TRANSFORMER CAN BE POWERED OFF THE HOT 120 VAC LINE BEFORE IT ENTERS THE FURNACE.

- DO NOT WIRE TRANSFORMER INTO FURNACE BLOWER CIRCUIT.

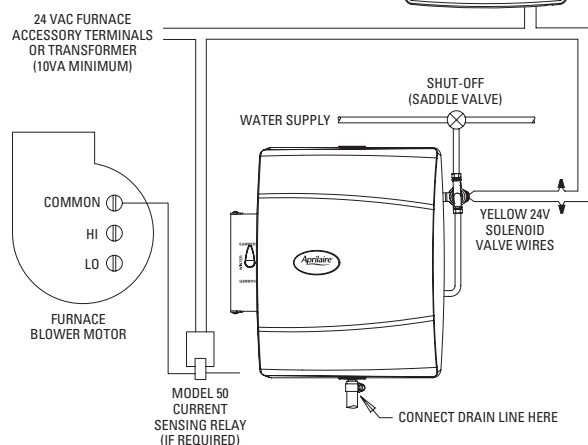

IMPORTANT

WHEN MODEL 50 CURRENT SENSING RELAY IS USED:

- WIRE MODEL 50 CURRENT SENSING RELAY INTO 24 VAC HUMIDIFIER CONTROL CIRCUIT ONLY!
- DO NOT INSTALL IN TRANSFORMER PRIMARY CIRCUIT.

90-1207

Model 500A AUTOMATIC DIGITAL HUMIDIFIER CONTROL

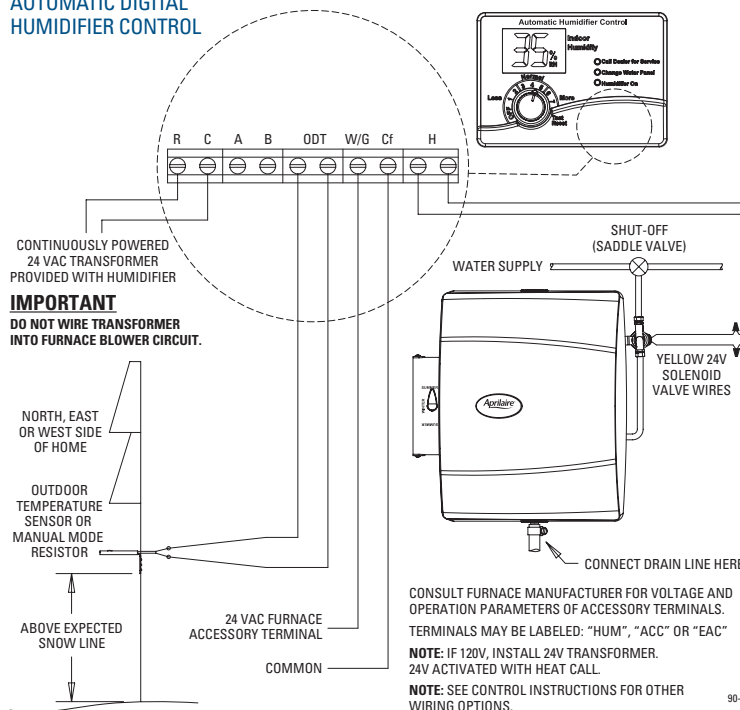

IMPORTANT

DO NOT WIRE TRANSFORMER INTO FURNACE BLOWER CIRCUIT.

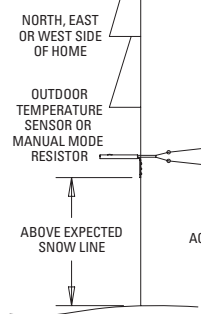

CONSULT FURNACE MANUFACTURER FOR VOLTAGE AND OPERATION PARAMETERS OF ACCESSORY TERMINALS.
NOTE: IF 120V, INSTALL 24V TRANSFORMER. 24V ACTIVATED WITH HEAT CALL.
NOTE: SEE CONTROL INSTRUCTIONS FOR OTHER WIRING OPTIONS.

90-1204

INSTALLATION OPTIONS

The Model 500M and 500A Aprilaire can be installed on either the supply or return plenum of a forced air handling system and is easily reversible for installation with right hand or left hand bypass duct connections. The humidifier dimensions and serviceability must be considered when selecting the best location for the humidifier. Here are 2 examples of many types of installations.

Upflow

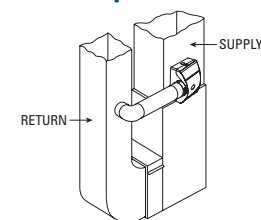

Horizontal

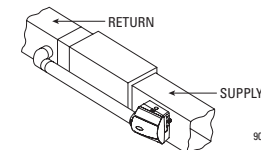

NOTE

When installing Aprilaire humidifier on a heat pump system, use hot water. The heated water supplements the reduced supply air temperature as added heat for evaporation.

90-1079

READ REVERSE SIDE FIRST!

- TOP -

READ REVERSE SIDE FIRST!

READ COMPLETE SAFETY INSTRUCTIONS AND INSTALLATION TEMPLATE BEFORE STARTING

FURNISHED ITEMS

- Built-in bypass damper
- 24 VAC Transformer
- Manual Humidifier Control (Model 500M only)
- Automatic Digital Humidifier Control (Model 500A only)
- Humidifier Control Installation Instructions
- Saddle valve
- Humidifier Installation Template

ITEMS NOT FURNISHED

- Mounting screws (sheet metal screws)
- Water supply line (1/4" copper)
- Drain line (1/2" I.D. hose)
- Low voltage wire
- Bypass ductwork
- Model 50 Current Sensing Relay (if required)

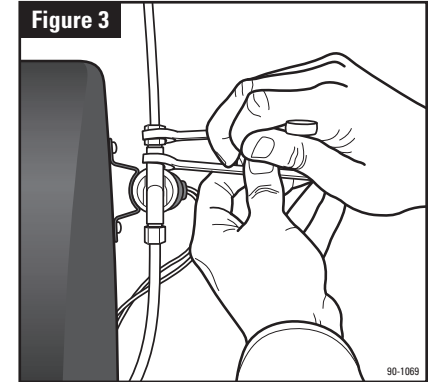
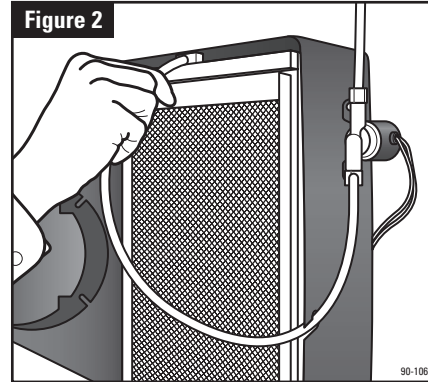
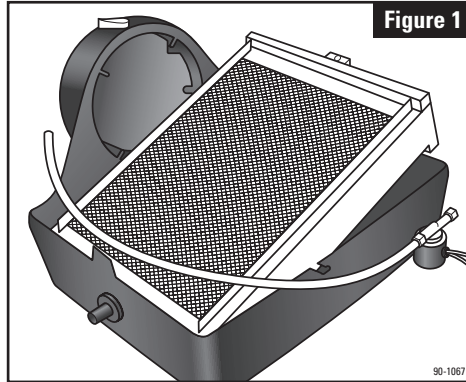

1. Press top & bottom tabs to remove cover (1). Pull feed tube (3) out of distribution tray (4). Remove Water Panel® Evaporator assembly. See **Figure 1**.

2. Humidifier is supplied with bypass duct connection on left. For right side bypass, swap location of drain spud (9) and cap (10). Twist to remove spud and cap.

3. Position template on supply or return plenum. Make sure template is level. Allow clearance for drain line and for servicing. Trace template outline. Cut 9-1/2" x 9-1/2" opening. **Avoid injury from sharp edges.**

4. Place humidifier base (2) in opening and secure with 6 screws in openings provided.

5. Select location for 6" collar on opposite plenum to minimize length and number of elbows in bypass duct. Install 6" bypass duct components. Attach duct to humidifier collar using 2 screws in openings provided.

6. Insert Water Panel Evaporator assembly into base. Make sure bottom of scale control insert (6) is in drain spud. Snap top of evaporator assembly into base.

Insert feed tube into distribution tray. See **Figure 2**. Rotate nameplate (11) if necessary, so it is right side up. Place point bypass damper handle (8) to "WINTER" (open) for heating season and "SUMMER" for cooling season.

7. Control installation and wiring. **Disconnect electrical power to furnace before wiring control.** In order for humidifier to operate, furnace must be on and RH must be below set-point of control. Wiring diagrams illustrate recommended method of detecting furnace operation.

MANUAL HUMIDIFIER CONTROL, MODEL 500M:

Manual Control can be mounted in return duct or on wall in living space. Knob and cover must be removed to mount control. See wiring diagram for 24V control connections.

- For return duct mounting, position template at least 6" upstream of bypass duct connection or humidifier. **Avoid injury from sharp edges when cutting opening.** Make sure foam gasket is in place and secure control to duct using 2 screws in openings provided.

- For wall-mount, select location that will not be affected by drafts or heat sources. Remove and discard foam gasket and secure control to wall over wire access opening using screws & anchors provided.

AUTOMATIC DIGITAL HUMIDIFIER CONTROL, MODEL 500A:

- Select location for control on return duct at least 6" upstream of bypass duct connection or humidifier. Position template on duct and mark location of RH sensor opening. Drill 3/4" hole for sensor. Knob and cover must be removed to mount control. Place control on duct with RH sensor extending into duct opening. Make sure gasket is in place around sensor cage. Secure humidistat to duct using 2 screws in openings provided.

- Control must be powered by a continuous 24 V source. See wiring

diagrams on template and control instructions for 24 V control connections.

8. Humidifier will function with cold, hot, softened or unsoftened water. Hot water (140°F max) will provide maximum evaporative capacity. Saddle valve provided may be used to tap into water supply. See installation instructions on saddle valve package. Saddle valve is designed to be fully opened or closed. Do not use to regulate flow.

9. Run 1/4" copper tubing from saddle valve to solenoid valve. **DOUBLE-WRENCH TO PREVENT LEAKING.** See **Figure 3**.

10. Run 1/2" I.D. hose from drain spud to floor drain. Make sure drain has constant downward slope and is not kinked. Do not over-tighten hose clamp onto drain spud. Do not use solvent adhesive on drain spud.

11. Check humidifier operation. Open saddle valve and turn control to highest setting. Turn on furnace. Allow humidifier to run until water flows from drain. Make sure all electrical connections are secure and all plumbing connections are watertight. Set control to proper setting.

PARTS LIST

1. Front Cover
2. Base
3. Feed Tube
4. Water Distribution Tray
5. Water Panel Evaporator
6. Scale Control Insert
7. Integral Damper
8. Damper Handle
9. Drain Spud
10. Hole Plug
11. Nameplate
12. Solenoid Valve

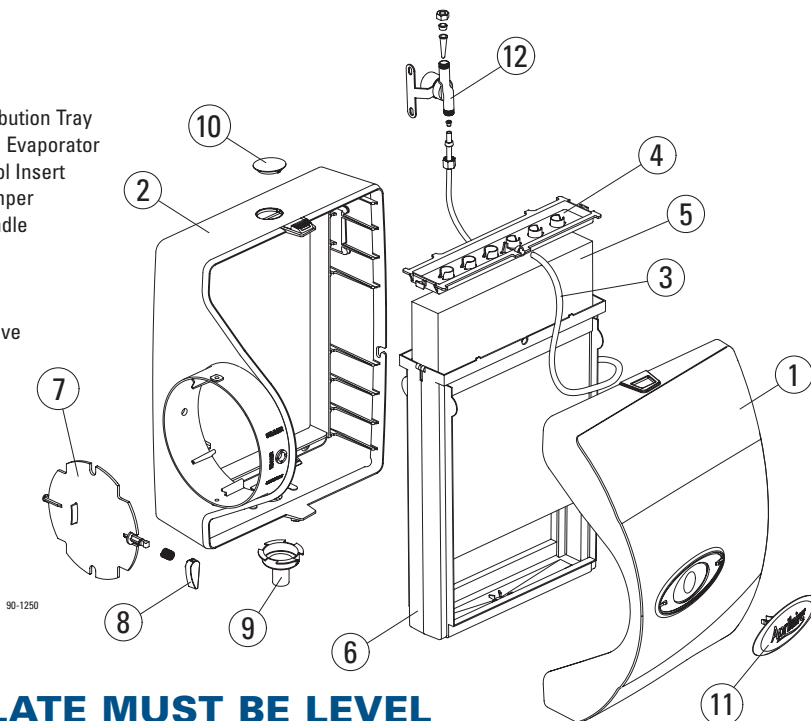

TEMPLATE MUST BE LEVEL

NOTE: BEFORE LEAVING THE JOB SITE, MAKE SURE:

1. Saddle valve is fully open.
2. All plumbing connections are watertight.
3. Humidifier functions properly.
4. Bypass damper is in proper position.

IMPORTANT! Be sure owner's manual containing instructions for operation and warranty information is given to owner in order to avoid unnecessary calls. Warranty is void unless humidifier is installed by qualified heating and air conditioning contractor due to possible misapplication of product.